

**St. Johns County School District**  
Sebastian Administrative Annex  
Purchasing Department  
3015 Lewis Speedway, Building 5  
St. Augustine, FL 32084



# INVITATION TO BID (ITB)

## REQUIRED RESPONSE FORM

BID NO.: 2018-42  
RELEASE DATE: December 21, 2018

**INVITATION TO BID TITLE: Storm Front and Store Front Doors**

F.O.B. Destination: **District Wide**

CONTACT: Patrick Snodgrass  
Director of Purchasing  
(904) 547-8941  
patrick.snodgrass@stjohns.k12.fl.us

**BID DUE DATE AND TIME: January 24, 2019 @ 1:30 pm**  
**BID OPENING DATE AND TIME: January 24, 2019 @ 2:00 pm**

SUBMIT BID TO: Sebastian Administrative Annex  
Purchasing Department  
3015 Lewis Speedway, Building 5  
St. Augustine, FL 32084

BID OPENING LOCATION: Sebastian Administrative Annex  
Purchasing Department  
3015 Lewis Speedway, Building 5  
St. Augustine, FL 32084

**REQUIRED SUBMITTALS CHECKLIST** - Each submittal checked below is **required** for Bid to be considered.

- Literature     Specifications     Catalogs     Product Samples: See Special Conditions  
 Debarment Form     Manufacturer's Certificate of Warranty  
 Drug-Free Workplace Certification     List of References  
 Certificate of Insurance: See Special Conditions  
 Additional submittals specific to this ITB may also be required – See Special Conditions for details

**BIDDER MUST FILL IN THE INFORMATION LISTED BELOW AND SIGN WHERE INDICATED FOR BID TO BE CONSIDERED.**

Company Name: \_\_\_\_\_

Address: \_\_\_\_\_

City, State: \_\_\_\_\_ Zip: \_\_\_\_\_ FEIN: \_\_\_\_\_

**Signature of Owner or Authorized Officer/Agent** \_\_\_\_\_ Telephone: \_\_\_\_\_

Typed Name of Above: \_\_\_\_\_ FAX: \_\_\_\_\_

Email: \_\_\_\_\_

By my signature, I certify that this offer is made without prior understanding, agreement, or connection with any corporation, firm, business entity or person submitting an offer for the same materials, supplies, equipment, or services (s), and is in all respects fair and without collusion or fraud. I further agree to abide by all conditions of this invitation and certify that I am authorized by the offeror to sign this response. In submitting an offer to the School Board of St. Johns County, I, as the Bidder, offer and agree that if the offer is accepted, the offeror will convey, sell, assign, or transfer to the School Board of St. Johns County all right, title, and interest in and to all causes of action it may now or hereafter acquire under the Anti-trust laws of the United States and the State of Florida for price fixing relating to the particular commodity(s) or service(s) purchased or acquired by the School Board. At the School Board's discretion, such assignment shall be made and become effective at the time the School Board of St. Johns County tenders final payment to the vendor.

## GENERAL CONDITIONS, INSTRUCTIONS AND INFORMATION

Bidder: To ensure acceptance of the bid follow these instructions:

1. **DEFINITIONS:** For purpose of these General Conditions "ITB" refers to the Invitation to Bid. "Bid" refers to the completed ITB Required Response Form above, together with all supporting documentations and submittals. "Bidder" or "Contractor" or "Respondent" refers to the entity or person that submits the Bid. "District" refers to the St. Johns County School District, and "School Board" to the St. Johns County School Board. "Purchasing Department Representative" refers to the Purchasing Department staff member named as its contact on the first page of the ITB. "Conditions" refers to both the General Conditions and the Special Conditions of this ITB.
2. **EXECUTION OF BID:** The ITB Required Response Form must be completed, signed, and returned in a sealed envelope to the Purchasing Department, together with the Bid and all required submittals. All Bids must be completed in ink or typewritten. If a correction is necessary, draw a single line through the entered figure and enter the corrected figure or use an opaque correction fluid. All corrections should be initialed by the person signing the Bid even when using opaque correction fluid. Any illegible entries will not be considered for award. The ITB General Conditions, Special Conditions and specifications **cannot** be changed or altered in any way by the Bid or otherwise by the Bidder. In the event of any conflict between the Conditions and specifications of the ITB and the terms and conditions of the Bid, the Conditions and specifications of the ITB take precedence. Any failure to comply with the ITB Conditions or specifications or attempt to alter them by the Bidder shall be grounds for rejection of the Bid.
3. **SUBMISSION OF BID:** The completed Bid must be submitted in a sealed envelope with the ITB title and bid number on the outside. Bids must be time stamped by the Purchasing Department prior to the ITB due time on date due. No Bid will be considered if not time stamped by the Purchasing Department prior to the stated submission deadline. Bids submitted by telegraphic or facsimile transmission will not be accepted unless authorized by the Special Conditions of this ITB.
4. **SPECIAL CONDITIONS:** The Purchasing Department has the authority to issue Special Conditions as required for a particular ITB. Any Special Conditions that vary from these General Conditions shall take precedence over the General Conditions.
5. **PRICES QUOTED:** Deduct trade discounts and quote a firm net price. Give both unit price and aggregate total. Prices must be stated in units to quantity specified in the ITB. In case of discrepancy in computing the amount of the Bid, the **Unit Price** quoted will govern. All prices quoted shall be F.O.B. destination, freight prepaid. Bidder is responsible for freight charges. Bidder owns goods in transit and files any claims, unless otherwise stated in Special Conditions. Each item must be proposed separately and no attempt is to be made to tie any item or items in with any other item or items. If a Bidder offers a discount or offers terms less than Net 30, it is understood that a minimum of thirty (30) days will be required for payment. If a payment discount is offered, the discount time will be computed from the date of satisfactory delivery at place of acceptance and receipt of correct invoice at the office specified.
  - a) Taxes: The School Board does not pay Federal excise and State taxes on direct purchase of tangible personal property. The applicable tax exemption number is shown on the purchase order. This exemption does not apply to purchases of tangible personal property made by contractors who use the tangible personal property in the performance of contracts for the improvement of School Board-owned real property as defined in Chapter 192 of the Florida Statutes.
  - b) Mistakes: Bidders are expected to examine the General and Special Conditions, specifications, delivery schedules, Bid prices and extensions, and all instructions pertaining to supplies and services. Failure to do so will be at Bidder's risk.
  - c) Conditions and Packaging: It is understood and agreed that any item offered or shipped as a result of this ITB shall be new (current production model at the time of this ITB) unless otherwise stated. All containers shall be suitable for storage or shipment, and all prices shall include standard commercial packaging.
  - d) Underwriters' Laboratories: Unless otherwise stipulated in the ITB, all manufactured items and fabricated assemblies shall be U.L. listed where such has been established by U.L. for the item(s) offered and furnished. In lieu of the U.L. listing, Bidder may substitute a listing by an independent testing laboratory recognized by OSHA under the Nationally Recognized Testing Laboratories (NRTL) Recognition Program.
  - e) Preference for St. Johns County Bidders: For all purchases made by the School Board, prices and quality being equal, preference may be given to St. Johns County Bidders, subject to certification as a drug-free workplace (Florida Statutes 287.087 and 287.084).
6. **BRAND NAMES:** The District reserves the right to invite Bids for a particular product or specific equipment by manufacturer, make, model or other identifying information. However, a Bidder may propose a substitute product of equal quality and functionality unless the Conditions or specifications state that substitute products or equipment may not be proposed and will not be considered. If a substitute product is proposed, it is the Bidder's responsibility to submit

with the Bid brochures, samples and/or detailed specifications on the substitute product. The District shall be the sole judge in the exercise of its discretion for determining whether the substitute product is equal and acceptable.

7. **QUALITY:** The items proposed must be new and equal to or exceed specifications. The manufacturer's standard warranty shall apply. During the warranty period, the successful Bidder must repair and/or replace the unit without cost to the District with the understanding that all replacements shall carry the same warranty as the original equipment. The successful Bidder shall make any such repairs and/or replacements immediately upon receiving notice from the District.
8. **SAMPLES:** Samples of items, when required, must be furnished free of expense by the ITB due date unless otherwise stated. If not destroyed, upon request, samples will be returned at the Bidder's expense. Bidders will be responsible for the removal of all samples furnished within thirty (30) days after ITB opening. All samples will be disposed of after thirty (30) days. Each individual sample must be labeled with Bidder's name, ITB number, and item number. Failure of Bidder to either deliver required samples or to clearly identify samples as indicated may be reason for rejection of the ITB. Unless otherwise indicated, samples should be delivered to the office of the Purchasing Department of the St. Johns County School Board, Sebastian Administrative Annex, 3015 Lewis Speedway Building 5, St. Augustine, FL 32084.
9. **TESTING:** Items proposed may be tested for compliance with ITB Conditions and specifications.
10. **NON-CONFORMITY:** Items delivered that do not conform to ITB Conditions or specifications may be rejected and returned at Bidder's expense. Goods or services not delivered as per delivery date in ITB and/or purchase order may be purchased on the open market. The Bidder shall be responsible for any additional cost. Any violation of these stipulations may also result in Bidder being disqualified from participating in future competitive solicitations or otherwise doing business with the District.
11. **DELIVERY:** Unless actual date of delivery is specified (or if specified delivery cannot be met), the Bid must show the number of days required to make delivery after receipt of purchase order in space provided. Delivery time may become a basis for recommending an award (see Special Conditions).
12. **REQUESTS FOR CLARIFICATION:** No correction or clarification of any ambiguity, inconsistency or error in the ITB Conditions and specifications will be made to any Bidder orally. Any request for such interpretation or correction should be by email addressed to the Purchasing Department Representative prior to the deadline specified in the Special Conditions for submitting questions. All such interpretations and supplemental instructions will be in the form of written addenda to the ITB. Only the interpretation or correction so given by the Purchasing Department Representative, by email or in writing, shall be binding and prospective Bidders are advised that no other source is authorized to give information concerning, or to explain or interpret the ITB Conditions and specifications.
13. **DISPUTE:** Any dispute concerning the Conditions or specifications of this ITB or the contract resulting from this ITB shall be decided by Purchasing Department and that decision shall be final.
14. **AWARDS:** Bids shall be reviewed in accordance with the ITB Conditions and specifications and the best interest of the School District. To that end, the Board reserves the right to reject any and all Bids; to waive any irregularities or informalities; to accept any item or group of items; to request additional information or clarification from any Bid; to acquire additional quantities at prices quoted in the Bid unless additional quantities are not acceptable, in which case the Bid must be conspicuously labelled "BID IS FOR SPECIFIED QUANTITY ONLY", and to purchase the product or service at the price and terms of any contract with a governmental entity procured by competitive solicitation, in accordance with Florida law. The decision to award a contract or take other action in regard to the ITB shall be made in the best interest of the School District.
15. **OTHER GOVERNMENTAL AGENCIES:** It is the intent of this solicitation to obtain Bids to sell the services or products to the School Board. Other school boards and governmental agencies/entities may purchase goods or services based on the contract awarded as a result of this ITB. The services and products are to be furnished in accordance with the terms of the resulting contract.
16. **MARKING:** A packing list must be included in each shipment and shall show the School Board purchase order number, ITB number, school name or department name, contents and shipper's name and address; mark packing list and invoice covering final shipment "Order Completed". If no packing list accompanies the shipment, the buyer's count will be accepted. Mark each package clearly with (A) shipper's name and address, (B) contents, (C) the School Board of St. Johns County purchase order number, and (D) ITB number.
17. **INSPECTION, ACCEPTANCE & TITLE:** Inspection and acceptance will be at destination shown on purchase order unless otherwise provided. Title to/or risk of loss or damage to all items shall be the responsibility of the successful Bidder until acceptance by the District. If the materials or services supplied to the District are found to be defective or do not conform to specifications, the Board reserves the right to cancel the order upon written notice to the Bidder and return product at Bidder's expense.
18. **BILLING AND PAYMENT:** Invoices, unless otherwise indicated, must show purchase order numbers and shall be submitted to St. Johns County School District, Accounts Payable Department, 40 Orange Street, St. Augustine, FL 32084. Payment will be made as prescribed in the Special Conditions and properly invoiced.

19. **COPYRIGHT AND PATENT RIGHTS:** The Bidder, without exception, shall indemnify and hold harmless the School Board and its employees from liability of any nature or kind, including legal fees and other costs and expenses, for or on account of any copyrighted, patented, or unpatented invention, process, or article manufactured or used in the performance of the contract, including its use by the School Board. If the Bidder uses any design, device, or materials covered by letters, patent, or copyright, it is mutually understood and agreed without exception that the Bid prices shall include all royalties or cost arising from the use of such design, device or materials in any way involved in the work.
20. **OSHA:** The Bidder warrants that the product supplied to the School Board shall conform in all respects to the standards set forth in the Occupational Safety and Health Act of 1970, as amended, and the failure to comply with this condition will constitute a breach of contract.
21. **LEGAL REQUIREMENTS:** The Bidder shall comply with Federal, State, County, and local laws, ordinances, rules, and regulations that in any manner affect the items covered herein. Lack of knowledge by the Bidder will in no way be a cause for relief from responsibility.
22. **CONFLICT OF INTEREST:** The award hereunder is subject to the provisions of Chapter 112, Florida Statutes. All Bidders must disclose with their Bid the name of any officer, director, or agent who is also an employee of the School Board. Further, all Bidders must disclose the name of any Board employee who owns directly or indirectly, an interest of five percent (5%) or more of the total assets of capital stock in the Bidder's firm.
23. **ANTI-DISCRIMINATION:** The Bidder certifies that Bidder is in compliance with the requirements of law regarding equal employment opportunity for all persons without regard to age, race, color, religion, sex, national origin, or disability.
24. **LICENSES AND PERMITS:** The Bidder shall be responsible for obtaining, at its expense, all licenses and permits required for performance of the work or services resulting from the ITB award.
25. **BID BONDS, PERFORMANCE BONDS, CERTIFICATES OF INSURANCE:** Bid bonds, when required, shall be submitted with the Bid in the amount specified in Special Conditions. Bid bonds will be returned to unsuccessful Bidders. After acceptance of Bid, the Board will notify the successful Bidder to submit a performance bond and certificate of insurance in the amount specified in Special Conditions. St. Johns County School District shall be named as additional insured on policies required by detailed specifications. Upon receipt of the performance bond, the Bid bond will be returned to the successful Bidder.
26. **DEFAULT AND REMEDIES:** The following remedies for default shall apply.
  - a) **Failure to Timely Deliver.** The parties acknowledge and agree that the damages for the failure of the successful Bidder to timely deliver the products or services contracted for may be difficult to determine. Moreover, both parties wish to avoid lengthy delay and expensive litigation relating to the failure of the successful Bidder to deliver on time. Therefore, in the event the successful Bidder fails to timely deliver the products or services contracted for, the School Board may exercise the remedy of liquidated damages against the successful Bidder in an amount equal to 25% of the unit price Bid, times the quantity. The successful Bidder shall pay that sum to the School Board not as a penalty, but as liquidated damages intended to compensate for unknown and unascertainable damages.
  - b) **Other Default.** In the event of default for any reason other than the failure of the successful Bidder to timely deliver the products or services contracted for, the School Board may exercise any and all remedies in contract or tort available to it, including, but not limited to, the recovery of actual and consequential damages.
27. **TERMINATION:** In the event any of the provisions of this ITB are violated by the Bidder, the Purchasing Department reserves the right to reject its Bid. Furthermore, the School Board reserves the right to terminate any contract resulting from this ITB for financial or administrative convenience, as determined in its sole business judgment, upon giving thirty (30) days prior written notice to the other party.
28. **FACILITIES:** The Board reserves the right to inspect the Bidder's facilities at any time with prior notice.
29. **ASBESTOS STATEMENT:** All material supplied to the School Board must be 100% asbestos free. Bidder by virtue of proposing, certifies by signing Bid, that if awarded any portion of this Bid, will supply only material or equipment that is 100% asbestos free.
30. **INDEMNITY AND HOLD HARMLESS AGREEMENT:** During the term of this Bid and any contract awarded to Bidder as a result of this ITB, the Bidder shall indemnify, hold harmless, and defend the School Board, its agents, and employees from any and all costs and expenses, including but not limited to, attorney's fees, reasonable investigative and recovery costs, court costs and all other sums which the Board, its agents, servants and employees, may pay or become obligated to pay on account of any, all and every claim or demand, or assertion of liability, or any claim or actions founded, thereon, arising or alleged to have arisen out of the products, goods or services furnished by the Bidder, its agents, or employees, or any of its equipment, including, without limitation, claims for damages, injury to person or property, including the Board's property, or death.
31. **CRIMINAL BACKGROUND SCREENING:** Pursuant to Florida Statute 1012.467 and School Board Rule 7.142, the District will issue and recognize statewide background badges to non-instructional contractor employees who meet the clearance requirements of Florida Statute 1012.467(2)(g) when it is not anticipated that they will come into direct contact with students. However, pursuant to Florida Statute 1012.467 and School Board Rule 7.142, if the District is unable to

rule out that Bidder's employees or subcontractors may come into contact with students, then, in the paramount interest of student safety, the employees will be required to undergo and pass background screening in accordance with School Board Rule 7.142, unless another statutory exemption applies.

**For this ITB:**

- A.  Student contact not anticipated
- B.  Student contact anticipated

If Box A is checked, statewide badge will be recognized or issued, if requested and the contractor meets clearance requirements.

If Box B is checked, background screening pursuant to School Board Rule 7.142(4) will be required.

**The Bidder acknowledges and agrees to comply with the requirements of School Board Rule 7.142. Bidder shall be responsible for the expense of the background screening of its employees.**

- 32. **VENUE:** Any suit, action, or other legal proceedings arising out of or relating to any contract awarded based upon this ITB shall be brought in a court of competent jurisdiction in St. Johns County, Florida. The parties waive any right to require that a suit, action, or proceeding arising out of this Agreement be brought in any other jurisdiction or venue.
- 33. **WAIVER OF JURY TRIAL:** The parties knowingly, voluntarily, and intentionally waive their right to trial by jury with respect to any litigation arising out of, under, or in connection with this ITB or any contract awarded upon this ITB. This provision is a material inducement for the School Board to enter into a contract with the successful Bidder.
- 34. **LOBBYING:** Lobbying is not permitted with any District personnel or School Board members in connection with any ITB or competitive solicitation. All oral or written inquiries must be directed through the Purchasing Department. Lobbying is defined as any action taken by an individual, firm, association, joint venture, partnership, syndicate, corporation, and all other groups who seek to influence the governmental decision of a board member or district personnel on the award of this contract. Any Bidder or any individuals that lobby on behalf of Bidder will result in rejection/disqualification of said Bid.
- 35. **ASSIGNMENTS:** The successful bidder may not sell, assign or transfer any of its rights, duties or obligations under Bid contract without the prior written consent of the School Board.
- 36. **PROTEST:** Failure to give notice or file a protest within the time prescribed in Section 120.57 (3), Florida Statutes, shall constitute a waiver of any protest.
- 37. **COMPLIANCE WITH FEDERAL REGULATIONS:** All contracts involving Federal funds will contain certain provisions required by applicable sections of Title 34, Section 80.36(l) and 85.510, Code of Federal Regulations and are included by reference herein.
  - a) **Debarment:** The Bidder certifies by signing the Bid and required response form that the Bidder and its principals are not presently debarred, suspended, proposed for debarment, declared ineligible or voluntarily excluded from participation in Federally funded transactions and may, in certain instances, be required to provide a separate written certification to this effect.

During the term of any contract with the School Board, in the event of debarment, suspension, proposed debarment, declared ineligible or voluntarily excluded from participation in Federally funded transactions, the Bidder shall immediately notify the Purchasing Department and the Superintendent, in writing.
  - b) **Records:** Vendors will also be required to provide access to records, which are directly pertinent to the contract and retain all required records for three (3) years after the School Board's final **payment is made**.
  - c) **Termination:** For all contracts involving Federal funds, in excess of \$10,000, the School Board reserves the right to terminate the contract for cause as well as convenience by issuing a certified notice to the vendor.
- 38. **PUBLIC ENTITY CRIME:** Pursuant to Florida Statute 287.133, a person or affiliate who has been placed on the convicted vendor list following a conviction for a public entity crime may not submit a Bid on a contract to provide any goods or services to a public entity, may not submit a Bid on a contract with a public entity for the construction or repair of a public building or public work, may not submit Bids on leases of real property to a public entity, may not be awarded or perform work as a contractor, supplier, subcontractor, or consultant under a contract with any public entity, and may not transact business with any public entity in excess of the threshold amount provided in Section 287.017 of Florida Statute, for CATEGORY TWO for a period of thirty-six (36) months from the date of being placed on the convicted vendor list.
- 39. **COLLECTION, USE OR RELEASE OF SOCIAL SECURITY NUMBERS:** The St. Johns County School District is authorized to collect, use or release social security numbers (SSN) of vendors, contractors and their employees and for the following purposes, which are noted as either required or authorized by law to be collected. The collection of social security numbers is either specifically authorized by law or imperative for the performance of the District's duties and responsibilities as prescribed by law (Sections 119.07(5)(a)2 and 3, Florida Statutes):

- a) **Criminal history and criminal background checks/Identifiers for processing fingerprints by Department of Law Enforcement/, if SSN is available** [Required by Fla. Admin. Code 11 C-6.003 and Fla. Stat. § 119.07(5)(a)6]
- b) **Vendors/Consultants that District reasonably believes would receive a 1099 form if a tax identification number is not provided including for IRS form W-9** [Required by 26 C.F.R. § 31.3406-0, 26 C.F.R. § 301.6109-1, and Fla. Stat. § 119.07(5)(a)2 and 6]

**40. PURCHASING AGREEMENTS AND STATE TERM CONTRACTS:** The Purchasing agreements and state term contracts available under s. 287.056 have been reviewed.

**41. PUBLIC RECORDS AND CONFIDENTIALITY:** Subject to the limited confidentiality afforded pending competitive solicitation by Florida Statute 119.071, the ITB and all Bids are public records subject to disclosure pursuant to the Florida Public Records Law. Requests for tabulations and other records pertinent to the competitive solicitation shall be processed in accordance with the Florida Public Records Law. By submitting a Bid, Bidders will be deemed to have waived any claim of confidentiality based on trade secrets, proprietary rights, or otherwise.

Florida Statute 119.0701 requires the Contractor to comply with Florida's public records laws with respect to services performed on behalf of the School District. Specifically, the Statute requires that the Contractor:

- a) Keep and maintain public records required by the School District to perform the service.
- b) Upon request from the School District's custodian of public records, provide the School District with a copy of the requested records or allow the records to be inspected or copied within a reasonable time at a cost that does not exceed the cost provided in Chapter 119 of the Florida Statutes or as otherwise provided by law.
- c) Ensure that public records that are exempt or confidential and exempt from public records disclosure requirements are not disclosed except as authorized by law for the duration of the contract term and following completion of the contract if the Contractor does not transfer the records to the School District.
- d) Upon completion of the contract, transfer, at no cost, to the School District all public records in possession of the Contractor or keep and maintain public records required by the School District to perform the service. If the Contractor transfers all public records to the School District upon completion of the contract, the contractor shall destroy any duplicate public records that are exempt or confidential and exempt from public records disclosure requirements. If the contractor keeps and maintains public records upon completion of the contract, the contractor shall meet all applicable requirements for retaining public records. All records stored electronically must be provided to the School District, upon request from the School District's custodian of public records, in a format that is compatible with the information technology systems of the School District.

**IF THE CONTRACTOR HAS QUESTIONS REGARDING THE APPLICATION OF CHAPTER 119, FLORIDA STATUTES, TO THE CONTRACTOR'S DUTY TO PROVIDE PUBLIC RECORDS RELATING TO THIS CONTRACT, CONTACT THE CUSTODIAN OF PUBLIC RECORDS AT 904-547-7637; [sjpubrec@stjohns.k12.fl.us](mailto:sjpubrec@stjohns.k12.fl.us) ; OR ST. JOHNS COUNTY SCHOOL BOARD, ATTN: COMMUNITY RELATIONS, 40 ORANGE STREET, ST. AUGUSTINE, FL 32084**

# Certification Regarding Debarment, Suspension, Ineligibility and Voluntary Exclusion - Lower Tier Covered Transactions

*This certification is required by the Department of Education regulations implementing Executive Order 12549, Debarment and Suspension, 34 CFR Part 85, for all lower tier transactions meeting the threshold and tier requirements stated at Section 85.110.*

1. By signing and submitting this proposal, the prospective lower tier participant is providing the certification set out below.
2. The certification in this clause is a material representation of fact upon which reliance was placed when this transaction was entered into. If it is later determined that the prospective lower tier participant knowingly rendered an erroneous certification, in addition to other remedies available to the Federal Government, the department or agency with which this transaction originated may pursue available remedies, including suspension and/or debarment.
3. The prospective lower tier participant shall provide immediate written notice to the person to whom this proposal is submitted if at any time the prospective lower tier participant learns that its certification was erroneous when submitted or has become erroneous by reason of changed circumstances.
4. The terms "covered transaction," "debarred," "suspended," "ineligible," "lower tier covered transaction," "participant," "person," "primary covered transaction," "principal," "proposal," and "voluntarily excluded," as used in this clause, have the meanings set out in the Definitions and Coverage sections of rules implementing Executive Order 12549. You may contact the person to which this proposal is submitted for assistance in obtaining a copy of those regulations.
5. The prospective lower tier participant agrees by submitting this proposal that, should the proposed covered transaction be entered into, it shall not knowingly enter into any lower tier covered transaction with a person who is debarred, suspended, declared ineligible, or voluntarily excluded from participation in this covered transaction, unless authorized by the department or agency with which this transaction originated.

6. The prospective lower tier participant further agrees by submitting this proposal that it will include the clause titled "Certification Regarding Debarment, Suspension, Ineligibility, and Voluntary Exclusion - Lower Tier Covered Transactions," without modification, in all lower tier covered transactions and in all solicitations for lower tier covered transactions.
7. A participant in a covered transaction may rely upon a certification of a prospective participant in a lower tier covered transaction that it is not debarred, suspended, ineligible, or voluntarily excluded from the covered transaction, unless it knows that the certification is erroneous. A participant may decide the method and frequency by which it determines the eligibility of its principals. Each participant may, but is not required to, check the Nonprocurement List.
8. Nothing contained in the foregoing shall be construed to require establishment of a system of records in order to render in good faith the certification required by this clause. The knowledge and information of a participant is not required to exceed that which is normally possessed by a prudent person in the ordinary course of business dealings.
9. Except for transactions authorized under paragraph 5 of these instructions, if a participant in a covered transaction knowingly enters into a lower tier covered transaction with a person who is suspended, debarred, ineligible, or voluntarily excluded from participation in this transaction, in addition to other remedies available to the Federal Government, the department or agency with which this transaction originated may pursue available remedies, including suspension and/or debarment.

## Instructions for Certification:

1. The prospective lower tier participant certifies, by submission of this proposal that neither it nor its principals are:
  - (a) presently debarred, suspended, proposed for debarment, declared ineligible, or voluntarily excluded from participation in this transaction by any Federal department or agency;
  - (b) have not within a three-year period preceding this application been convicted of or had a civil judgment rendered against them for commission of fraud or a criminal offense in performing a public (federal, state or local) transaction or contract under a public transaction; or for violation of federal or state antitrust statutes or commission of embezzlement, theft, forgery, bribery, falsification or destruction of records, making false statements or receiving stolen property;
  - (c) are not presently indicted for or otherwise criminally or civilly charged by a government entity (federal, state or local) with commission of the offenses enumerated in this certification; or
  - (d) have not within a three-year period preceding this application had one or more public transaction (federal, state or local) terminated for cause or default.
2. Where the prospective lower tier participant is unable to certify to any of the statements in this certification, such prospective participant shall attach an explanation to this proposal.

Name of Applicant	PR/Award Number and/or Project Name
Printed Name	Title of Authorized Representative
Signature	Date

## DRUG FREE WORKPLACE CERTIFICATION FORM

In accordance with 287.087, Florida Statutes, preference shall be given to businesses with drug-free workplace programs. Whenever two or more bids, which are equal with respect to price, quality, and service, are received by the state or by any political subdivision for the procurement of commodities or contractual services, a bid received from a business that certifies that it has implemented a drug-free workplace program *shall be given preference* in the award process. Established procedures for processing tie bids will be followed if none of the tied vendors have a drug-free workplace program. In order to have a drug-free program, a business shall:

- 1) Publish a statement notifying employees that the unlawful manufacture, distribution, dispensing, possession, or use of a controlled substance is prohibited in the workplace and specifying the action that will be taken against employees for violations of such prohibition.
- 2) Inform employees about the dangers of drug abuse in the workplace, the business's policy of maintaining a drug-free workplace, any available drug counseling, rehabilitation, and employee assistance programs, and the penalties that may be imposed upon employees for drug abuse violations.
- 3) Give each employee engaged in providing the commodities or contractual services that are under bid a copy of the statement specified in subsection (1).
- 4) In the statement specified in subsection (1), notify the employees that, as a condition of working on the commodities or contractual services that are under bid, the employee will abide by the terms of the statement and will notify the employer of any conviction of, or plea of guilty or nolo contendere to, any violation of chapter 893 or of any controlled substance law of the United States or any state, for a violation occurring in the workplace no later than five (5) days after such conviction.
- 5) Impose a sanction on, or require the satisfactory participation in a drug abuse assistance or rehabilitation program if such is available in the employee's community, by any employee who is so convicted.
- 6) Make a good faith effort to continue to maintain a drug-free workplace through implementation of this section.

As the person authorized to sign the statement, I certify that this firm complies fully with the above requirements.

\_\_\_\_\_  
(Vendor's Signature)





**BIDDER'S STATEMENT OF PRINCIPAL PLACE OF BUSINESS**

(Must be completed & submitted with each competitive solicitation)

Bid number and description: \_\_\_\_\_

Identify the state in which the Vendor has its principal place of business: \_\_\_\_\_

**Instructions: IF your principal place of business above is located within the State of Florida, the Vendor must sign below and submit this form with your bid response, no further action is required.**

**However, if your principal place of business is outside of the State of Florida, the following must be completed by an attorney and returned with your bid response. FAILURE TO COMPLY SHALL BE CONSIDERED TO BE NON-RESPONSIVE TO THE TERMS OF THE SOLICITATION.**

**OPINION OF OUT –OF-STATE BIDDER'S ATTORNEY ON BIDDING PREFERENCES**

(To be completed by the Attorney for an Out-of-State Vendor)

**NOTICE:** Section 287.084(2), Florida Statute, provides that “a vendor whose principal place of business is outside this state must accompany any written bid, proposal, or reply documents with a written opinion of an attorney at law licensed to practice law in that foreign state, as to the preferences, if any or none, granted by the law of that state (or political subdivision thereof) to its own business entities whose principal places of business are in that foreign state in the letting of any or all public contracts.” See also: Section 287.084(1), Florida Statutes.

**LEGAL OPINION ABOUT STATE BIDDING PREFERENCES**

(Please Select One)

\_\_\_\_ The Vendor's principal place of business is in the State of \_\_\_\_\_ and it is my legal opinion that the laws of that state **do not grant a preference** in the letting of any or all public contracts to business entities whose principal places of business are in that state.

\_\_\_\_ The Vendor's principal place of business is in the State of \_\_\_\_\_ and it is my legal opinion that the laws of that state **grant the following preference(s)** in the letting of any or all public contracts to business entities whose principal places of business are in that state: (Please describe applicable preference(s) and identify applicable preference(s) and identify applicable state law(s)):

\_\_\_\_\_  
\_\_\_\_\_

**LEGAL OPINION ABOUT POLITICAL SUBDIVISION BIDDING PREFERENCES**

(Please Select One)

\_\_\_\_ The Vendor's principal place of business is in the political subdivision of \_\_\_\_\_ and it is my legal opinion that the laws of that political subdivision **do not grant a preference** in the letting of any or all public contracts to business entities whose principal places of business are in that political subdivision.

\_\_\_\_ The Vendor's principal place of business is in the political subdivision of \_\_\_\_\_ and the laws of that political subdivision **grant the following preference(s)** in the letting of any or all public contracts to business entities whose principal places of business are in that political subdivision: (Please describe applicable preference(s) and identify applicable authority granting the preference(s)):

\_\_\_\_\_  
\_\_\_\_\_

Signature of out-of-state Vendor's attorney: \_\_\_\_\_

Attorney's printed name: \_\_\_\_\_

Address of out-of-state Vendor's attorney: \_\_\_\_\_

Phone number/e-mail of out-of-state Vendor's attorney: \_\_\_\_\_

Attorney's states of bar admission: \_\_\_\_\_

Vendor's Signature: \_\_\_\_\_

Vendor's Printed Name: \_\_\_\_\_

**Bid #2018-42 Storm Front and Store Front Doors**

**ST. JOHNS COUNTY SCHOOL DISTRICT**

**INVITATION TO BID**

**SPECIAL CONDITIONS**

**1.0 INTRODUCTION**

1.1 The St. Johns County School District (hereinafter referred to as the District) is requesting bid pricing from qualified vendors for the replacement and installation of impact resistant and non-impact resistant Storm Front and Store Front doors, percentage markup for other doors and materials, and hourly labor rate for other work at various schools and facilities throughout the District. All work performed under this bid will be on an as needed basis. The District makes no guarantee of a specific volume of work to be performed under this bid.

**2.0 INSTRUCTIONS FOR BID SUBMITTAL**

2.1 All bids must be received no later than, January 24, 2019 @ 1:30 PM and must be delivered to:

St. Johns County School District  
Sebastian Administrative Annex  
Purchasing Department  
3015 Lewis Speedway, Building 5  
St. Augustine, FL 32084

If a bid is transmitted by US mail or other delivery medium, the bidder will be responsible for its timely delivery to the address indicated

2.2 Any bid received after the stated date and time, **WILL NOT** be considered.

2.3 One manually signed original bid and one photocopy of the bid must be sealed in one package and clearly labeled "Bid #2018-42 Storm Front and Store Front Doors" on the outside of the package. The legal name, address, bidder's contact person and telephone number must also be clearly noted on the outside of the package.

2.4 Failure to submit one original bid with a manual signature may result in rejection of the bid.

2.5 All bids must be signed by an officer or employee having the authority to legally bind the bidder.

2.6 Any corrections must be initialed. This includes corrections made using correction fluid (white out) or any other method of correction.

2.7 Bidders should become familiar with any local conditions that may, in any manner, affect the services required. The bidder(s) are required to carefully examine the bid terms and

## **Bid #2018-42 Storm Front and Store Front Doors**

to become thoroughly familiar with any and all conditions and requirements that may in any manner affect the work to be performed under the contract. No additional allowance will be made due to lack of knowledge of these conditions.

- 2.8 Bids not conforming to the instructions provided herein will be subject to disqualification at the sole discretion of the District.
- 2.9 Any bid may be withdrawn prior to the date and time the bids are due. Any bid not withdrawn will constitute an irrevocable offer for a period of 90 days, to provide the District with the services specified in the bid.
- 2.10 Pursuant to Florida Statute, it is the practice of the District to make available for public inspection and copying any information received in response to an Invitation to Bid or Request for Proposal (RFP). No action on the part of the respondent to a Bid or RFP will create an obligation of confidentiality on the part of the District, including but not limited to, making a reference in the response to the trade secret statutes. It is recommended that potential suppliers exclude from their response any information that, in their judgment may be considered a trade secret.
- 2.11 When a school district is required to make purchases of personal property through competitive solicitation and the lowest responsible and responsive bid, proposal or reply is by a vendor whose principal place of business is in a state or political subdivision which grants a preference by that state or political subdivision, then the school district shall award an equal preference to the lowest responsible and responsive vendor having a principal place of business within Florida. In a competitive solicitation in which the lowest bid is submitted by a vendor whose principal place of business is located outside the state, and that state does not grant a preference in competitive solicitation to vendors having a principal place of business in that state, the preference to the lowest responsible and responsive vendor having a principal place of business in the State of Florida shall be five (5) percent. F.S. 287.084(1)(a).

A vendor whose principal place of business is outside this state must accompany any written bid, proposal or reply documents with a written opinion of an attorney at law licensed to practice law in that foreign state, as to the preferences, if any or none, granted by the law of that state to its own business entities whose principal places of business are in that foreign state in the letting of any or all public contracts. F.S. 287.084(2).

### **3.0 AWARD**

- 3.1 The District reserves the right to waive any irregularities and technicalities and may, at its sole discretion, request a re-submittal or other information to evaluate any or all bids.
- 3.2 The District reserves the right to require bidder(s) to submit evidence of qualifications or any other information the Board may deem necessary, including audited and unaudited financial statements.
- 3.3 The District reserves the right, prior to Board approval, to withdraw the bid or portions thereof, without penalty.

## **Bid #2018-42 Storm Front and Store Front Doors**

- 3.4 The District reserves the right to: (1) accept the bid of any firm to be in the best interest of the District and (2) to reject any and/or all bids.
- 3.5 The District reserves the right to conduct interviews with any of the bidders and to require a formal presentation by any of the bidders.
- 3.6 It is the intent of the District to award this bid to one or more sources, as determined to be in the best interest of the District.
- 3.7 The bid award will be made based on funds availability and will be at the sole discretion of the St. Johns County School Board.

### **4.0 CONTRACT/RENEWAL**

- 4.1 The term of this contract shall be from March 11, 2019 to March 10, 2020 and may by mutual agreement between the District and the awarded vendor be renewable for up to three (3) additional one (1) year periods.
- 4.2 All terms and conditions of this bid, any addenda, and negotiated terms are incorporated into the contract by reference as set forth herein.

### **5.0 BID INQUIRIES/NOTICES**

- 5.1 In order to maintain a fair and impartial competitive process, prospective bidders shall not communicate with District staff or Board members after bids are released. All questions and inquiries must be submitted via email no later than January 7, 2019 @ 12:00 PM to:

Patrick Snodgrass  
Director of Purchasing  
[patrick.snodgrass@stjohns.k12.fl.us](mailto:patrick.snodgrass@stjohns.k12.fl.us)

**Communication via email as stated above is the only means prospective bidders may contact the District regarding this solicitation. Violation of this section is grounds for automatic disqualification of a prospective bidder's submittal.**

All questions will be answered via posting to the DemandStar website [www.demandstar.com](http://www.demandstar.com) no later than January 9, 2019 @ 5:00 PM.

The District will not respond to questions and inquiries submitted after the deadline stated above.

- 5.2 Copies of addendum will be made available for inspection at the District's Purchasing Department where bid documents will be kept on file.
- 5.3 No Addendum will be issued later than January 9, 2019, except an addendum withdrawing the Invitation to Bid or one which includes postponement of the date for receipt of bids or one containing the questions and answers.

## **Bid #2018-42 Storm Front and Store Front Doors**

5.4 All notices relative to this Bid, including but not limited to initial release, addendums, letters of intent and awards will be posted on the DemandStar web site – [www.demandstar.com](http://www.demandstar.com).

### **6.0 SCOPE OF SERVICES**

6.1 The bid is for the replacement and installation of impact resistant and non-impact resistant Storm Front and Store Front doors, other doors and materials, percentage markup for other doors and materials, and hourly labor rate for other work at various schools and facilities throughout the District. All work performed under this bid will be on an as needed basis. The District makes no guarantee of a specific volume of work to be performed under this bid.

6.2 The awarded vendor is responsible for supplying, at its own expense, all supervision, labor, tools, equipment, materials, transportation, licenses and anything necessary to perform work under this bid. The District will not purchase, lease or otherwise acquire any equipment for use by the awarded vendor in performance of work under this bid.

6.3 All Storm Front and Store Front doors must meet or exceed specifications listed in **Attachment A**.

6.4 The awarded vendor will coordinate the installation, repair or other work with an authorized District representative.

6.5 All doors are to be fully operational upon completion of the installation and in accordance with specifications, regulations and codes.

6.6 Prior to any work, the awarded vendor will be required to provide a written job quote for each job performed. The bid pricing submitted on the bid sheet will be used as the basis for each job quote. The requirements of each job will be determined by an authorized District representative. If other work or materials have been requested each job quote must contain a detailed listing of the labor and materials required to complete the work based on the individual requirements of each job. The listing of product must include the appropriate unit of measurement, quantity and cost to the District. Any materials awarded based on a percentage (%) markup over cost must show the vendors cost and the appropriate markup.

6.7 The awarded vendor shall provide itemized invoices for hours worked and goods/materials received which are to reflect the prices submitted on the bid sheet. No additional charges may be incurred by the District. The District reserves the right to require the awarded vendor to provide documentation to substantiate their labor and material cost for other work.

6.8 Any increase to the work shall be performed only after execution of a written change order by an authorized District representative and a revised purchase order. The District reserves the right to inspect all work prior to payment. Final project approval is contingent on the final inspection by an authorized District representative. The awarded vendor shall promptly correct all work rejected by an authorized District representative as defective.

## **Bid #2018-42 Storm Front and Store Front Doors**

- 6.9 The awarded vendor is responsible for any and all costs associated with removal and disposal of the existing doors and for all clean up of the site. Rubbish and/or debris will NOT be deposited in to the District's refuse containers.
- 6.10 It shall be the sole responsibility of the awarded vendor to safeguard their own materials, tools, and equipment. The District shall not assume any responsibility for vandalism and/or theft of materials, tools and/or equipment.
- 6.11 The awarded vendor shall be responsible for any damage to District property, personnel property or visitor property due to negligence on the part of the awarded vendor, its employees or agents. The awarded vendor agrees to repair, at its own expense, any damage that was caused to District property by the awarded vendor, its employees or agents.

### **7.0 BID PRICING**

- 7.1 Bidders are required to submit a price for all Storm Front and Store Front doors. This price must include all ancillary material and installation costs, debris removal, and any needed equipment rental. The District will not be responsible for any cost above that included in the bid price.
- 7.2 Bidders are required to submit a percentage (%) markup over cost for other doors.
- 7.3 Bidders are required to submit a percentage (%) markup over cost for other materials.
- 7.4 Bidders are required to submit an hourly labor rate for repair and other work on an as needed basis. The billable hourly rate shall start upon arrival at the job site and end upon departure from the site.
- 7.5 Bidders are required to indicate the amount of time to respond to an emergency call for repair work to any facility within the District.
- 7.6 No mileage or fuel charges will be incurred by the District.
- 7.7 The bid sheet must be signed by an individual of the bidding firm that has the authority to bind the firm.

### **8.0 QUALIFICATIONS**

All bidders responding to this bid must possess a current business tax receipt and must submit a copy as part of their bid submittal.

### **9.0 REFERENCES**

All bidders must provide a minimum of three (3) references whom they have performed similar services for within the past five (5) years.

### **10.0 INSURANCE REQUIREMENTS**

## **Bid #2018-42 Storm Front and Store Front Doors**

It is mandatory that the person/firm submitting the bid have minimum Liability limits of \$1,000,000.00 for both Comprehensive General Liability, including Product Liability Coverage. The person/firm submitting the bid must also have a minimum Liability Limit of \$1,000,000.00 for Motor Vehicle Liability and at least the statutory limit of Worker's Compensation. All coverage must be included on the certificate(s). Bidder's insurance provider must be rated A- or better by AM Best. If the bidder's current certificate of insurance does not meet the amount required, a statement must be included with the bid document from their insurance carrier indicating that if a bid award was made to the firm, that the carrier would write the necessary insurance coverage. The successful bidder must then have the required insurance placed in force with written notification provided to the Director of Purchasing, prior to issuance of a purchase order that authorizes the work performance to begin. Failure to do so may invalidate the award and result in an award to the next lowest responsible bidder. **Successful vendor must list St. Johns County School Board as an additional insured.**

### **11.0 VENDOR PAYMENT**

The St. Johns County School District requires all vendors responding to this bid to accept payment from the District on a Visa credit card. No other payment options will be made available. St. Johns County School District will issue a unique "ghost" credit card number to each vendor. This information must be held on file for all future payments. The card has a zero balance until payments have been authorized by the district.

After goods are delivered or services rendered vendors submit invoices to the Accounts Payable Department according to the current process. The payment terms are set as IMMEDIATE (next accounts payable run). When payments are authorized, an email notification is sent to an email address provided by the vendor. The email notification includes the invoice number, invoice date, and amount of payment. Once the vendor receives the email the credit card has been authorized to charge for the amount listed in the email. When the vendor charges the full amount authorized in the email the card will return to a zero balance until the next payment is authorized.

### **12.0 PURCHASE ORDERS**

A Purchase Order issued by the Purchasing Department or from School Internal Accounts is the only legal authorization for vendors to perform services or provide commodities to the District. A commitment, either written or verbal, from District employees without a Purchase Order issued by the Purchasing Department or from School Internal Accounts does not constitute an obligation by the District to a vendor. Vendors that perform services or provide commodities without a Purchase Order issued by the Purchasing Department or from School Internal Accounts do so at their own risk and at risk of non-payment. Additional information regarding doing business with the District can be found on the District web site, [www.stjohns.k12.fl.us](http://www.stjohns.k12.fl.us) under the Purchasing Department.

### **13.0 PREPARATION AND SUBMISSION OF BID**

13.1 Bidder's are requested to organize their bids in the following sequence.

## **Bid #2018-42 Storm Front and Store Front Doors**

- 13.2 **Invitation to Bid:** Required response form (page 1 of Bid) with all required information completed and all signatures as specified
- 13.3 **Debarment Form**
- 13.4 **Drug Free Workplace Certification**
- 13.5 **Principal Place of Business**
- 13.6 **Insurance Coverage:** Insurance certificates evidencing coverage as specified in section 10.0 or a signed statement indicating that coverage meeting the required coverage will be obtained prior to the commencement of any work under this bid.
- 13.7 **Qualifications**
- 13.8 **References**
- 13.9 **Bid Sheet**



	Bid Price
Purchase, Deliver and Install Single Storm Front Door - Impact Resistant	
Purchase, Deliver and Install Double Storm Front Doors - Impact Resistant	
Purchase, Deliver and Install Single Store Front Door - Non Impact Resistant	
Purchase, Deliver and Install Double Store Front Doors - Non Impact Resistant	
Percentage Mark Up Over Cost for Other Doors	
Percentage Mark Up Over Cost for Other Materials	
Hourly Labor Rate for Repair and Other Work	
Amount of Time to Respond to an Emergency Call for Repair Work	

Company Name: \_\_\_\_\_

Authorized Signature: \_\_\_\_\_

Print Name: \_\_\_\_\_

Date: \_\_\_\_\_

# STORM FRONT™

## Specifications

## Hurricane Resistant Storefronts

### SECTION 08 41 13 ALUMINUM STOREFRONTS

- Series IG500
- Series IG600

SERIES	FACE WIDTH	DEPTH	GLAZING INFILLS	GLAZING METHOD
IG500	2-1/2" (63.5)	5" (127)	9/16" (14)	Exterior
IG600	2-1/2" (63.5)	5" (127)	1-5/16" (33)	Exterior

#### I. GENERAL DESCRIPTION

Work Included: Furnish all necessary materials, labor, and equipment for the complete installation of aluminum framing as shown on the drawings and specified herein. (Specifier Note: It is suggested that related items such as aluminum entrance doors, glass, and sealants be included whenever possible).

Work Not Included: Structural support of the framing system, interior closures, trim. (Specifier list other exclusions). Related Work Specified Elsewhere: (Specifier list).

#### QUALITY ASSURANCE

Drawings and specifications are based on the Series (Specify) IG500 / IG600 system as manufactured by U.S. Aluminum. Whenever substitute products are to be considered, supporting technical literature, samples, drawings, and performance data must be submitted 10 days prior to bid in order to make a valid comparison of the products involved. Test reports certified by an independent test laboratory must be made available upon request.

#### PERFORMANCE REQUIREMENTS

**Air Infiltration:** Shall be tested in accordance with ASTM E 283-91.

Infiltration shall not exceed: Dade County Protocol TAS 202-94

- IG500 Storefront - 1.00 cfm/ft<sup>2</sup>  
@ 6.24 psf = (5.08 L/s/m<sup>2</sup>)
- IG500 Pair of Doors - 1.00 cfm/ft<sup>2</sup>  
@ 6.24 psf = (6.10 L/s/m<sup>2</sup>)

Outside Dade County

- IG500 / IG600 Storefront - 1.00 cfm/ft<sup>2</sup>  
@ 6.24 psf = (5.08 L/s/m<sup>2</sup>)
- IG500 / IG600 Pair of Doors - 1.00 cfm/ft<sup>2</sup>  
@ 6.24 psf = (5.08 L/s/m<sup>2</sup>)

**Water Infiltration:** Shall be tested in accordance with ASTM E 331-93. No water penetration at test pressure of: Dade County Protocol TAS 202-94

- IG500 Storefront - 12 psf
  - IG500 Pair of Doors - 12 psf (Water resistant threshold)
- Outside Dade County
- IG500 / IG600 Storefront - 12 psf
  - IG500 / IG600 Pair of Doors - 12 psf (Water resistant threshold)

**Structural Performance:** Shall be tested in accordance with ASTM 330-96 and based on:

- Maximum deflection of L/175 of the span. 3/4" (19.1) max.
  - Allowable stress with a safety factor of 1.65. The system shall perform to this criteria under a windload of (Specify) psf
- Dade County Protocol TAS 220-94
- IG500 Storefront
    - Design 65 psf (159 mph)
    - Structural +/- 97.5 psf (195 mph)
  - IG500 Pair of Doors
    - Design 65 psf (159 mph)
    - Structural +/- 97.5 psf (195 mph)
- Outside Dade County
- IG500 Storefront
    - Design 65 psf (159 mph)
    - Structural +/- 97.5 psf (195 mph)
    - Design 75 psf (171 mph)
    - Structural +/- 112.5 psf (210 mph)
  - IG500 Pair of Doors
    - Design 65 psf (159 mph)
    - Structural +/- 97.5 psf (195 mph)
    - Design 75 psf (171 mph)
    - Structural +/- 112.5 psf (210 mph)

**Forced Entry Resistance:** Shall be tested with a 300 lb. force applied to the active door panel simultaneously with a 150 lb. force applied in both perpendicular directions to the 300 lb. force.

Dade County Protocol TAS 220-94

- IG500 Pair of Doors

Outside Dade County

- IG500 / IG600 Pair of Doors

Large Missile Impact Test - Shall be tested in accordance with: Dade County Protocol TAS 201-94 with a 9 lb. 2x4 traveling at 50 fps.

- Dade County
- IG500 Storefront
  - IG500 Pair of Doors
- Outside Dade County
- IG500 / IG600 Storefront
  - IG500 / IG600 Pair of Doors

Cycle Load Test - Shall be tested in accordance with:

Dade County Protocol TAS 201-94 for 9,000 cycles.

- Dade County
- IG500 Storefront
  - IG500 Pair of Doors
  - IG500 / IG600 Storefront
  - IG500 / IG600 Pair of Doors

#### II. PRODUCTS MATERIALS

Extrusions shall be 6063-T5 alloy and temper (ASTM B221 alloy T5 temper). Fasteners, where exposed, shall be aluminum, stainless steel or zinc plated steel in accordance with ASTM A 164. Perimeter anchors shall be aluminum or steel, providing the steel is properly isolated from the aluminum. Glazing gaskets shall be E.P.D.M. elastomeric extrusions.

#### FINISH

Aluminum extrusions shall be given a caustic etch followed by an anodic oxide treatment to obtain ... (Specify one of the following):

- \_\_\_\_\_ #11 Clear anodic coating
- \_\_\_\_\_ #22 Dark Bronze anodic coating
- \_\_\_\_\_ #33 Black anodic coating

A Fluoropolymer paint coating conforming with the requirements of AAMA 2605. Color shall be (Specify a U. S. Aluminum standard color).



# STORM FRONT™

## Specifications

## Hurricane Resistant Storefronts

### SECTION 08 41 13 ALUMINUM STOREFRONTS

- Series IG500
- Series IG600

#### FABRICATION

The framing system shall provide for flush glazing on all sides with no projecting stops. Vertical and horizontal framing members shall have a nominal face dimension of 2-1/2" (63.5). Overall depth shall be 5" (127). Entrance framing members shall be compatible with glass framing in appearance. Provide for internal drainage of infiltrated water into an extruded aluminum subsill channel where it is drained to the exterior through weep slots.

#### GLAZING

Dade County

- IG500 Storefront - 9/16" (14) Heat strengthened with SentryGlas® Plus interlayer

- IG500 Pair of Doors - 9/16" (14) Heat strengthened with SentryGlas® Plus interlayer
- Outside Dade County
- IG500 Storefront and IG500 Pair of Doors. Glazing must meet Impact and Cycle Testing requirements according to Local Building Codes.
  - IG600 Storefront and IG600 Pair of Doors. 1-5/16" (33) Glazing must meet Impact and Cycle Testing requirements according to Local Building Codes.

#### SEALANTS

All metal-to-metal joints shall use DOW 795 Silicone. Door seal gaskets shall require small joint sealer.

#### III. EXECUTION INSTALLATION

All glass framing shall be set in correct locations as shown in the details and shall be level, square, plumb, and in alignment with other work in accordance with the manufacturer's installation instructions and approved shop drawings. All joints between framing and the building structure shall be sealed in order to secure a watertight installation.

#### PROTECTION AND CLEANING

After installation the General Contractor shall adequately protect exposed portions of aluminum surfaces from damage by grinding and polishing compounds, plaster, lime, acid, cement, or other contaminants. The General Contractor shall be responsible for final cleaning.



Project: Automotive Dealership, Atlanta, GA

Online [usalum.com](http://usalum.com) By Phone (800) 262-5151  
 Online [crlaurence.com](http://crlaurence.com) By Phone (800) 421-6144

# STORM FRONT™

## Special Features

## Hurricane Resistant Storefronts

- Series IG500
- Series IG600

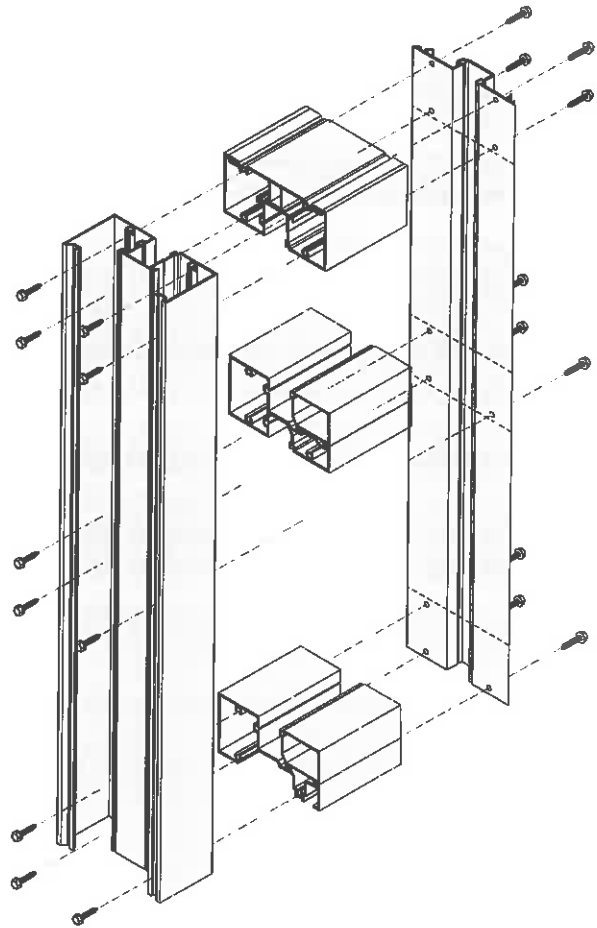
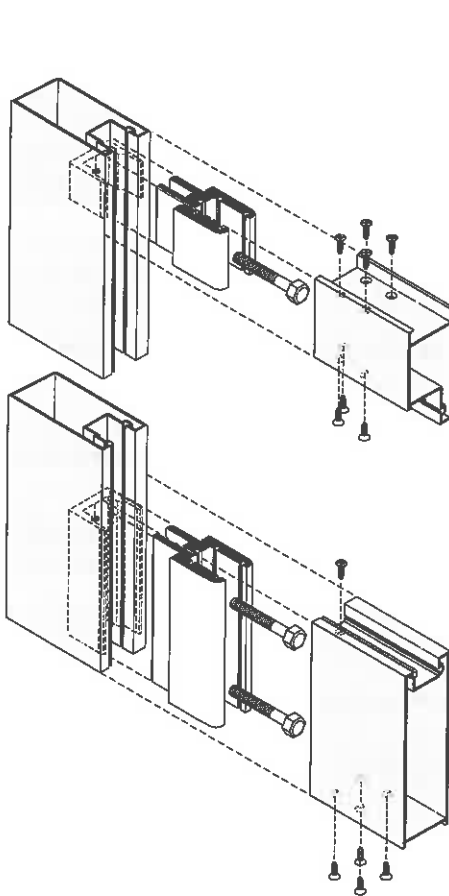

Storm Front™ Entrance Doors are 2-3/16" (55.6) thick with a .125" (3.2) wall thickness and feature a One Glass Stop Glazing System for clean sight lines on both sides of the door. Standard corner construction includes heavy-duty blocks. Corners are welded for maximum strength.

A low profile Air Resistant Threshold is offered for installations that have soffit overhangs greater than the entrance frame height. Check local codes for compliance.

High performance Water Resistant Thresholds are offered to provide superior water and air management, along with Ramps to meet A.D.A. requirements when required.

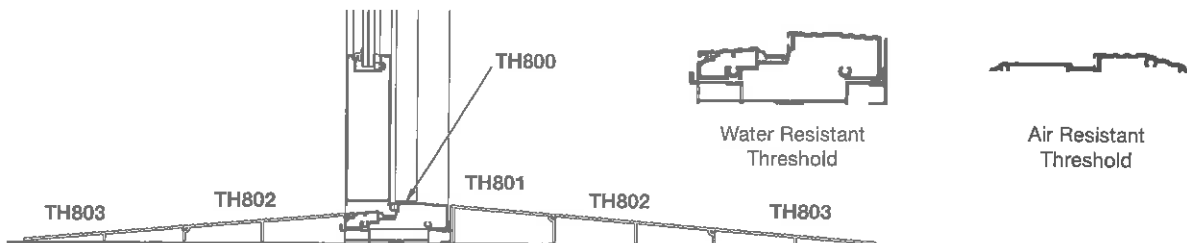

Online [usalum.com](http://usalum.com) By Phone (800) 262-5151  
Online [crlaurence.com](http://crlaurence.com) By Phone (800) 421-6144



# STOREFRONTS

## Specifications

### Center Glazed

- Series 400
- Series 450
- Series 451

### SECTION 08 41 13 ALUMINUM STOREFRONTS

SERIES	FACE WIDTH	DEPTH	GLAZING INFILLS	GLAZING METHOD
400	1-3/4" (44.5)	4" (101.6)	1/4" (6) or 3/8" (10)	Exterior/Interior
450	1-3/4" (44.5)	4-1/2" (114.3)	1/4" (6) or 3/8" (10)	
451	2" (50.8)	4-1/2" (114.3)	1" (25)	

#### I. GENERAL DESCRIPTION

Work Included: Furnish all necessary materials, labor, and equipment for the complete installation of aluminum framing as shown on the drawings and specified herein. (*Specifier Note: It is suggested that related items such as aluminum entrance doors, glass, and sealants be included whenever possible.*)

Work Not Included: Structural support of the framing system, interior closures, trim. (*Specifier list other exclusions.*)

Related Work Specified Elsewhere: (*Specifier list.*)

#### QUALITY ASSURANCE

Drawings and specifications are based on the Series (*Specify*) Center Glazed System as manufactured by U.S. Aluminum. Whenever substitute products are to be considered, supporting technical literature, samples, drawings, and performance data must be submitted 10 days prior to bid in order to make a valid comparison of the products involved. Test reports certified by an independent test laboratory must be made available upon request.

#### PERFORMANCE REQUIREMENTS

**Air Infiltration:** shall be tested in accordance with ASTM E 283. Infiltration shall not exceed .06 cfm per square foot (.0003m<sup>3</sup>/sm<sup>2</sup>) of fixed area when tested at 6.24 psf (300 Pa).

**Water Infiltration:** shall be tested in accordance with ASTM E 331. No water penetration at test pressure of

8 psf (384 Pa). When tested with the high performance subsill.

**Structural Performance:** shall be tested in accordance with ASTM E 330 and based on:

- Maximum deflection of L/175 of the span
- Allowable stress with a safety factor of 1.65

The system shall perform to this criteria under a windload of (*Specify*) psf.

Testing Procedures -

ASTM 283, E 331, and E 330 - Laboratory performance testing. AAMA 503-08 - Newly installed storefronts. AAMA 511-08 - Installed storefronts after six months.

#### II. PRODUCTS MATERIALS

Extrusions shall be 6063-T5 alloy and temper (ASTM B221 alloy T5 temper). Fasteners, where exposed, shall be aluminum, stainless steel or zinc plated steel in accordance with ASTM A 164. Perimeter anchors shall be aluminum or steel, providing the steel is properly isolated from the aluminum. Glazing gaskets shall be E.P.D.M. elastomeric extrusions.

#### FINISH

All exposed framing surfaces shall be free of scratches and other serious blemishes. Aluminum extrusions shall be given a caustic etch followed by an anodic oxide treatment to obtain...

(*Specify one of the following:*)

- \_\_\_\_ #11 Clear anodic coating
- \_\_\_\_ #22 Dark Bronze anodic coating
- \_\_\_\_ #33 Black anodic coating

A Fluoropolymer paint coating conforming with the requirements of AAMA 2605. Color shall be (*Specify a U.S. Aluminum standard color.*)

#### FABRICATION

The framing system shall provide for flush glazing on all sides with no projecting stops. Vertical and horizontal framing members shall have a nominal face dimension of (*Specify*). Overall depth shall be (*Specify*). Entrance framing members shall be compatible with glass framing in appearance. Provide for internal drainage of infiltrated water into an extruded aluminum subsill channel where it is drained to the exterior through weep slots.

#### III. EXECUTION INSTALLATION

All glass framing shall be set in correct locations as shown in the details and shall be level, square, plumb, and in alignment with other work in accordance with the manufacturer's installation instructions and approved shop drawings. All joints between framing and the building structure shall be sealed in order to secure a watertight installation.

#### PROTECTION AND CLEANING

After installation the General Contractor shall adequately protect exposed portions of aluminum surfaces from damage by grinding and polishing compounds, plaster, lime, acid, cement or other contaminants. The General Contractor shall be responsible for final cleaning.



# ENTRANCES

## Specifications

- Series 250
- Series 400
- Series 550

### SECTION 08 11 16 ALUMINUM DOORS AND FRAMES

SERIES	STILES	TOP RAIL	BOTTOM RAIL	GLAZING INFILL
250 Narrow Stile	2" (50.8)	2-1/8" (54)	3-3/16" (81)	1/4" (6) or 1" (25)
400 Medium Stile	3-1/2" (88.9)	3-3/16" (81)	6-1/2" (165.1)	1/4" (6) or 1" (25)
550 Wide Stile	5" (127)	5-1/2" (139.7)	6-1/2" (165.1)	1/4" (6) or 1" (25)
A.D.A. Bottom Rail Option for Any Series			9-1/2" (241.3)	

#### I. GENERAL DESCRIPTION

**Work Included:** The glazing contractor shall furnish all necessary materials, labor, and equipment for the complete installation of aluminum entrance doors, door frames, and hardware as detailed on the drawings and specified herein.

**Work Not Included:** Structural support of the framing system, wood framing, structural steel, masonry, and final cleaning.

#### QUALITY ASSURANCE

For purposes of designating type and quality for work in this section, drawings and specifications are based on one of the following U.S. Aluminum Series 250, 400 or 550 Entrance Doors.

**OPTIONAL:** Door shall have A.D.A. 9-1/2" (241.3) bottom rail.

When substitute products are to be considered, supporting technical literature, samples, and drawings must be submitted 10 days prior to bid date in order to make a valid comparison of the products involved.

#### II. PRODUCT MATERIALS

Door members shall be extruded architectural aluminum 6063-T5 alloy and temper. Major portions of all door sections, except glazing beads, shall be nominal .125 (3.2) inch. Wall thickness of frame members shall be nominal .093 (2.4) inch. Screws, nuts, washers, bolts, rivets, and other fastening devices shall be aluminum, stainless steel or other non-corrosive materials.

#### DOOR CONSTRUCTION

Door stiles and rails shall be tubular

sections accurately joined at corners with heavy concealed reinforcement brackets secured with bolts, screws, and then MIG welded. Doors shall have snap-in stops with E.P.D.M. glazing gasket on both sides of the glass. No exposed screws shall be permitted. Each door leaf shall be equipped with an adjusting mechanism, located in the top rail near the lock stile, which provides for minor clearance adjustments after installation.

A hard-backed poly-pile weatherstrip shall be installed in both stiles of center hung single doors and in hinge stiles of center hung pairs of doors. Offset pivoted or butt hung doors shall have weatherstripped doorstops at frame jambs and header. The active meeting stile of all pairs of doors shall have an adjustable astragal with a double line of weatherstripping.

**OPTIONAL:** Door bottom rail will be weatherstripped with an E.P.D.M. blade gasket sweep strip applied with concealed fasteners. (**NOTE:** This option is required for high performance conditions.)

**OPTIONAL:** Door bottom rail shall receive a concealed weatherstripped insert.

#### HARDWARE

Hardware for aluminum doors and door frames shall be the entrance manufacturer's standard. If custom hardware is to be furnished by others, templates and physical hardware must be submitted prior to any fabrication.

#### FINISH

All exposed framing surfaces shall be free of scratches and other serious

blemishes. Aluminum extrusions shall be given a caustic etch followed by an anodic oxide treatment to obtain... (*Specify one of the following*).

- \_\_\_\_\_ #11 Clear anodic coating
- \_\_\_\_\_ #22 Dark Bronze anodic coating
- \_\_\_\_\_ #33 Black anodic coating

A Fluoropolymer paint coating conforming with the requirements of AAMA 2605. Color shall be (*Specify a U.S. Aluminum standard color*).

#### III. EXECUTION INSTALLATION

All items under this heading shall be set in their correct locations as shown in the details and shall be level, square, plumb, at proper elevation and in alignment with other work in accordance with the manufacturer's installation instructions and approved shop drawings. All joints between entrance framing and the building structure shall be sealed in order to secure a watertight installation. Upon completion of the installation of the entrances, it shall be the contractor's responsibility to make all necessary final adjustments to attain normal operation of each door and its mechanical hardware.

#### PROTECTION AND CLEANING

After installation the General Contractor shall adequately protect exposed portions of the aluminum entrance work from damage by grinding and polishing compounds, plaster, lime, acid, cement or other contaminants. The General Contractor shall be responsible for final cleaning.

# ENTRANCES

## Technical Data

- Series 250
- Series 400
- Series 550

### FOR 1/4" (6) OR 1" (25) GLAZING

As an industry leader in the manufacture of entrance doors and frames, U.S. Aluminum consistently builds products to meet the highest industry standards, ensuring years of reliable service. Job-tested, mechanically fastened and welded corner construction creates a rugged structural corner assembly. All doors offer clean lines and are supplied with unique Astral II push/pull hardware and maximum security locks. These entrances can easily accommodate a wide variety of custom hardware for specific job requirements.

SERIES	STILES	TOP RAIL	BOTTOM RAIL	TRAFFIC APPLICATIONS
250 Narrow Stile	2" (50.8)	2-1/8" (54)	3-3/16" (81)	Light to Moderate
400 Medium Stile	3-1/2" (88.9)	3-3/16" (81)	6-1/2" (165.1)	Moderate to Heavy
550 Wide Stile	5" (127)	5-1/2" (139.7)	6-1/2" (165.1)	Heavy
A.D.A. Bottom Rail Option for Any Series			9-1/2" (241.3)	

#### STANDARD FEATURES:

**Glass Stops** - Pressure type glass stops (square or beveled) with E.P.D.M. glazing gaskets permit time saving installation of 1/4" (6) glass. Optional glass stops are available for 1" (25) infills. Setting blocks for glass are preset at the factory.

**Adjustable Leveling Screw** - A simple adjustment on the leveling screw, concealed in the top rail of the door, compensates for minor variances in door openings after installation.

**Adjustable Astragal** - All pairs of doors come with spring-loaded fully adjustable dual weathered astragals for optimum air resistance. Binding or gaps at the meeting stiles can be easily corrected by simple adjustments. The full length dual weather stripping on the astragal is not interrupted by the deadlock.

#### ACCESSORIES:

##### Hinging Hardware

- Offset Pivots for Single Acting Doors
- Butt Hinges for Single Acting Doors
- Concealed Center Pivots for Use With Double Acting Doors

##### Closers

- Exposed Overhead
- Concealed Overhead
- Floor

##### Panic Exit Devices

- Conventional Cross Bar
- Mid-Panel Panic

**Vanguard Security Astragal** - See page 16-A1.

#### \* MAXIMUM RECOMMENDED DOORS SIZES:

48" (1.219 m) X 96" (2.438 m)

\* Requires special hardware. Please consult with factory.

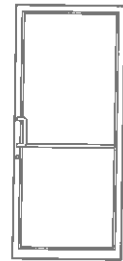

**Series 250 - Narrow Stile**  
(Offset hung door shown)

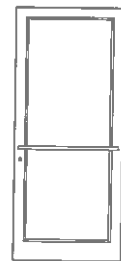

**Series 400 - Medium Stile**  
(Center hung door shown)

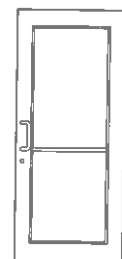

**Series 550 - Wide Stile**  
(Offset hung door shown)

# ENTRANCES

## Door Corner Construction

- Series 250
- Series 400
- Series 550

